

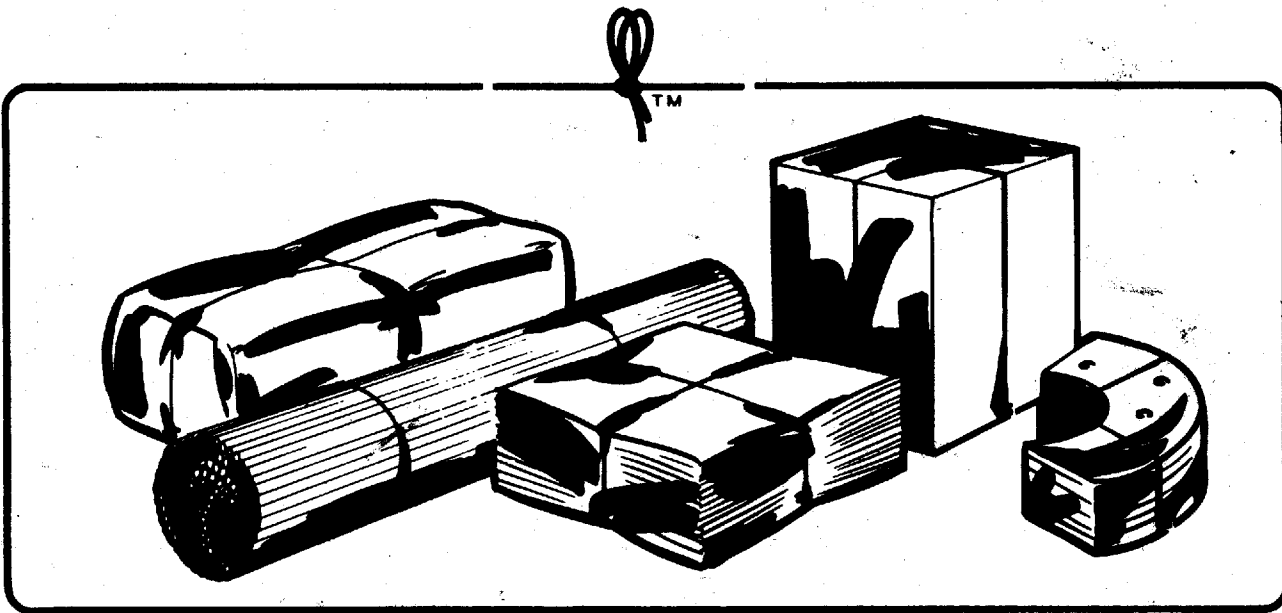

# BT-17

# TYING MACHINES OPERATOR'S MANUAL



SINCE 1907 THE ORIGINAL PACKAGE TYING MACHINE

**TYPAC**  
INC.

PO Box 425  
Baldwinsville, NY 13027  
800 356-8964 315 638-9431  
FAX 315 638-9433  
www.typac.com  
info@typac.com

Please call with serial number of machine  
that you would like parts for.

# **NOTICE**

**Do not attempt to operate this equipment before reading the operation instructions and performing the Before Operations Checks paragraph in Section 3 of this manual**

## **OPERATOR SAFETY REMINDERS**

The National Safety Council reminds us that most accidents are caused by the failure of some individual to follow simple and fundamental safety rules or precautions. For this reason, you, as a careful operator, are the best insurance against an accident.

Regardless of the care used in the design and construction of any type of equipment there are many conditions that cannot be completely safeguarded against without interfering with reasonable accessibility and efficient operation.

- **Never attempt to thread, clean, oil or adjust a machine while motor is operating or machine is in motion.**
- **Never operate machine with any guard or panels removed and keep hands away from inside of guard to avoid being struck by twine arm.**
- **Do not remove grounding prong from power cord.**

# TYING MACHINES OPERATOR'S MANUAL

## Foreword

This manual contains instructions for installation, operation, preventative maintenance, troubleshooting, and repair parts identification for your Tying Machine Model manufactured by the B. H. Bunn Company, Lakeland, Florida. Proper use of the manual should ensure safe and efficient operation and maintenance of the tying machine.

Because of the increasing staff of Service Rep-

resentatives, B. H. Bunn Company can now offer a Maintenance Contract. Contact your local Service Representative, who is capable to render factory approved service, for full detail maintenance contract information, or the B. H. Bunn Company.

This manual may not be reprinted or reproduced, either in whole or in part without written permission of the B. H. Bunn Company.

## CONTENTS

<b>SECTION I</b>	<b>PAGE</b>	<b>SECTION IV</b>	<b>PAGE</b>
Introduction.....	2	Lubrication Requirements .....	8
Purpose of Tying Machine .....	2	Maintenance.....	9
General Description.....	2	Introduction.....	9
Principles of Operation .....	2	Table of Lubrication Requirements .....	9
Basic Types of Different Wraps .....	3		
		<b>SECTION V</b>	
<b>SECTION II</b>		Troubleshooting .....	11
Preparation for Use .....	4	Table of Troubleshooting Information .....	11, 12
Power Requirements.....	4		
Tying Materials.....	4	<b>SECTION VI</b>	
Threading Procedures .....	5	Parts List .....	13
		Main Table Assembly .....	13
<b>SECTION III</b>		Knotter Head Assembly.....	15
Operation .....	6	Stringholder Assembly.....	17
Before Operation Checks.....	6	Main Cam Assembly.....	19
One-Way Wrap Operation.....	6	Kickout Mechanism.....	21
Cross-Wrap Operation .....	7	Mainshaft, Main Gear & Chain	
After Operation Procedures.....	7	Gear Assemblies .....	23
		Clutch Assemblies.....	25
		Twine Arm Assemblies.....	27
		Miscellaneous .....	29, 31

# Section I Introduction

## PURPOSE OF TYING MACHINE

The primary purpose of the tying machine is to automatically tie mail, packages, cartons, pieceparts, printed matter, newspapers, laundry, produce, meat, corrugated cardboard, and miscellaneous materials and products requiring a secure wrap.

The tying machine ties almost everything that was previously wired, banded, taped, strapped or previously tied by hand in offices, factories, and commercial establishments.

The tying machine reduces tying time, employee effort and fatigue, reduces twine lint and twine waste, enables trained operators to make secure ties quickly, ties larger bundles with greater ease and efficiency, and discourages tampering because the tied knot cannot be duplicated by hand tying.

## GENERAL DESCRIPTION

The tying machine (illustrated on the Characteristics Sheet at the front of the manual) consists of a main table assembly, knotter head assembly, and base parts.

The tying machine is of steel and cast iron construction. Caster wheels are provided for fast easy mobility.

All moving parts are enclosed except for the twine arm which is shielded by a twine arm guard to prevent accidental contact from the sides or rear of the tying machine.

Controls are located in the front of the tying machine within easy and comfortable reach of the operator. An operator's foot pedal provides the means to activate the tying machine.

Operator maintenance points are easily reached without the use of tools.

Refer to the Model Characteristics Sheet at the front of the manual for additional information for your tying machine model.

## PRINCIPLES OF OPERATION

With the tying machine power cord connected to an appropriate power source, the power switch set to the "on" position, the bundle to be tied properly positioned on the front table and back table, the tying cycle is started by the operator applying toe pressure to the foot pedal.

Power from the electric motor assembly is transferred to the drive assembly through the drive-belt. Through a series of gears, the drive assembly rotates the twine arm one, two or three revolutions around the bundle. As the twine travels through the twine arm and passes the drawslide during the final revolution, the drawslide snaps back allowing the twine to fall into position behind the stringholder button. The drawslide and tip-up then push and lift the twine across the knotter into position.

The knotter body assembly moves forward catching the twine and turns counter-clockwise opening its jaws for the two strands of twine which are wrapped around the knotter body assembly. The strands of twine are brought through the jaws and the jaws firmly lock. The knotter body assembly then moves toward its finished position and the stripper forces the twine strands off the knotter body assembly jaws into the tight parts of the knot. As the two strands of twine are pulled into loops from the knotter body assembly jaws, the knife trap moves forward, cuts a fresh end of twine and pulls the previously cut end of the twine from behind the stringholder button. The knotter body assembly completes its movement to the finished position and the knotter body assembly jaws to release the loops, completing the tying process.

The tied bundle is then removed from the tying machine.

# Basic Types of Different Wraps

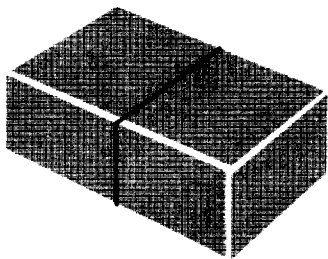

**Single Wrap** — The arm carries the twine around once and the knot is formed.

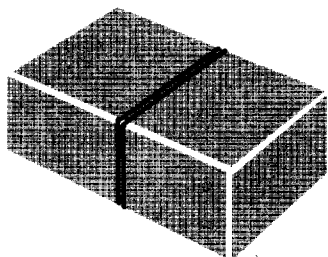

**Double Wrap — ONE WAY** Two wraps in one direction with one knot.

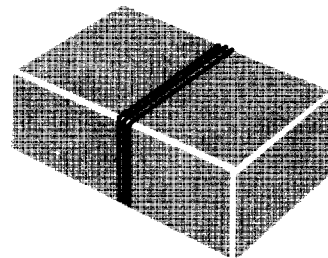

**Triple Wrap — ONE WAY** Three wraps in one direction with one knot.

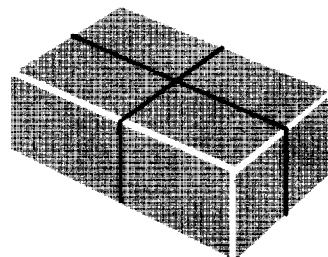

**Double Wrap\* — CROSS TIE** One wrap in each direction with only one knot.

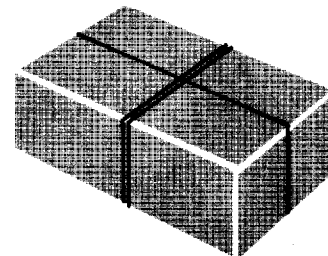

**Triple Wrap\*\* — CROSS TIE** One wrap in one direction; two wraps in other direction — with only one knot.

\*\*Triple wrap cross tie additionally provides: (1) three wraps in one direction if package is not turned between wrap cycles; (2) two wraps one way by tripping out the first wrap.

\*Double wrap cross tie also provides: (1) two wraps in one direction if package is not turned between wrap cycles; (2) one way by tripping out the first wrap.

# Section II Preparation For Use

## POWER REQUIREMENTS

The single-phase, ¼ hp, 1725 rpm standard motor provided with your tying machine requires an external power source of 115 volts at 60 cycles.

A standard three-prong electrical cord is provided with electrical motor. If a three-prong receptacle is not available at the installation site, a three-prong adapter should be used with the electrical cord.

## TYING MATERIALS

The tying machine is adaptable to a wide range of tying materials ranging from natural fibre twines to synthetics which can replace wire and strapping in many applications.

Be sure the twine or tape used is the proper type and size for the application and your Bunn machine. Each new or factory reconditioned Bunn Tying Machine is factory adjusted and set for a particular

size and type of twine. Other sizes or types will require adjustments and may require internal part changes.

The right Bunn Twine, tested and approved for Bunn Tying Machines, aids in maximum machine performance. Bunn Twine is of uniform size and strength, free of irregularities that cause misties. It is strong and fray-resistant, with minimum linting characteristics.

A free sample folder showing actual twine samples and specifications is available through your local B.H. Bunn Company Distributor.

Conversion kits are available through your B.H. Bunn Company factory representative when and if it ever becomes necessary to change to a different material-twine to tape or tape to twine.

The twine container will hold up to a 5-pound cone of twine. The base diameter of the cone must not exceed 9 inches.

# Threading Procedure

Before tying machine is shipped, it is threaded through each guide starting from the twine container to the stringholder button. To avoid threading problems in the future, you should become familiar with the threading sequence at this time.

Complete threading of the tying machine can be avoided if the end of the twine or tape being used is caught before it leaves the twine container. This is accomplished by simply tying the end of the existing

twine or tape to the starting end of the new twine or tape with a square knot.

If the end of the twine or tape is not caught before it leaves the twine container, the tying machine must be threaded as explained in the subsequent procedures.

It is important to observe the various openings which are identified by numbered labels affixed to the machine which the twine or tape is to be threaded.

**Never thread machine while motor is operating.**



FRONT

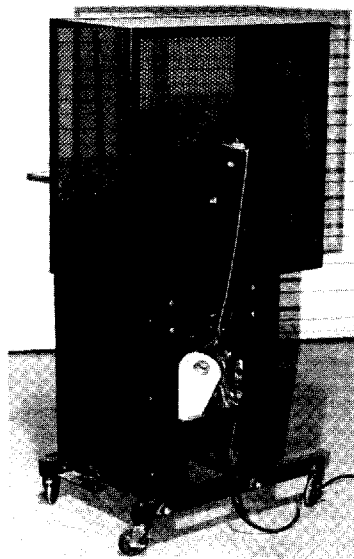

REAR

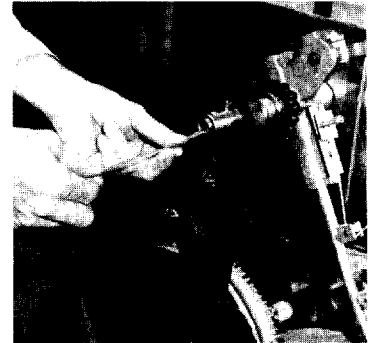

Place twine cone over cone pilot assembly. Press firmly until cone is seated on foam pad at bottom of twine container. Note: Cone pilot assembly is adjustable if cone does not seat properly. Grasping end of twine, thread through guide (label #1) and quill shaft (label #2) as illustrated.

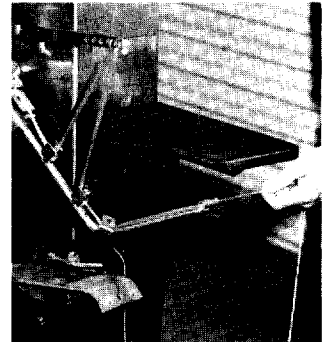
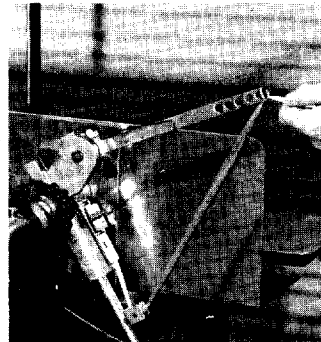
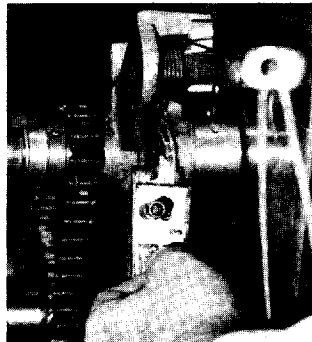

Fish twine out from quill shaft (label #3) on inside of machine. Thread twine through tension device under tension spring between rows of pins. Spring (label #4) may be lifted GENTLY to facilitate this procedure. Continue to thread through roller (label #5), end of drawback lever (label #6), rollers (labels #7 & #8) and tip of twine arm (label #9).

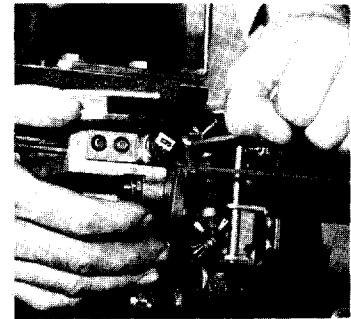
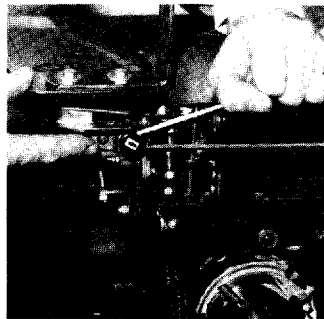

Pull twine to right side of machine. While depressing stringholder release lever, place twine under stringholder button (label #10). Pull twine or tape up and over button shaft and release stringholder release lever. Pull twine or tape taut and manually activate knife trap lever (as illustrated) to cut off excess twine.

# Section III Operation

## BEFORE OPERATION CHECKS

1. TURN MASTER SWITCH TO THE "OFF" POSITION.
2. Check for proper threading.
3. Check if twine or tape cone is properly seated on foam pad of twine container.
4. Check twine running tension by pulling twine from end of twine arm assembly. A smooth easy running tension should be felt.
5. Visually check tying machine for any mechanical defects or missing parts.
6. Verify that electrical power cord is inserted into receptacle and then set power switch to the "ON" position.

## TYING SIZE LIMITATIONS

The capacity graph on the Model Characteristics Sheet at the front of the manual indicates the maximum height and width of the packages that can be tied. Bunn tying machines adjust automatically to handle most packages of varying sizes and shapes that are smaller than its maximum capacity.

Throat depth is the distance from the back of the back table to the twine line, or the maximum distance you can slide the package into the tying machine. The "throat" depth is also tabulated on the Model Characteristics Sheet.

## ONE-WAY WRAP OPERATION

1. Stand in front of the tying machine at the operating position — the widest side of the fixed table.
2. Set power switch to "ON" position.
3. Hold ends of package between thumbs and forefingers of both hands and position package on tying machine table so that right side of package is butted against standard (figure 3) and positioned over gap between front and back tables.

4. Momentarily depress foot pedal holding package firmly until tying cycle is completed. The tying cycle is completed after the twine arm makes the required wraps, one, two, or three.

## NOTE

The tying machine automatically compensates for the size and shape and the different lengths of twine required. The tying machine also automatically applies the correct amount of tension, ties the patented slipproof and tamperproof knot and then cuts the twine.

5. Remove package from tying machine.
6. Repeat steps 3 through 5 above for each package to be tied.
7. After all packages have been tied, set power switch to "OFF" position.

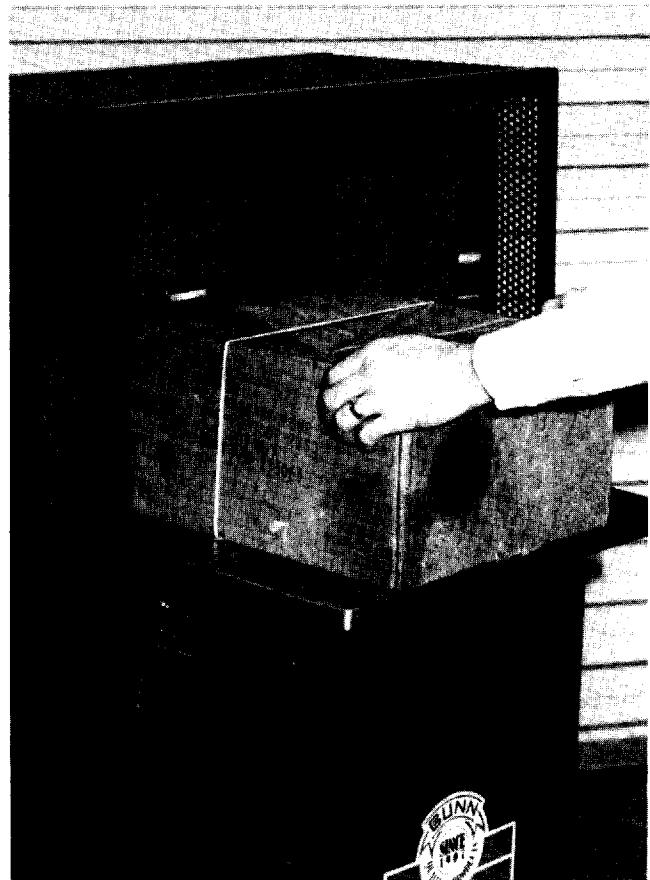



## CROSS WRAP OPERATION

1. Stand in front of the tying machine at the operating position — the widest side of the fixed table.
2. Set power switch to "ON" position.
3. Hold ends of package between thumbs and forefingers of both hands and position package on tying machine table so that right side of package is butted against standard or notch in front table (figure 4) and positioned over gap between front and back tables.
4. Momentarily depress foot pedal holding package firmly until tying arm completes one revolution.
5. Turn package 90 degrees IN CLOCKWISE DIRECTION (figure 4) in tying machine.
6. Depress foot pedal (second time) holding package firmly until tying cycle is completed.
7. Remove package from tying machine.

8. Repeat steps 3 through 6 above for each package to be tied.
9. After all packages have been tied, set power switch to "OFF" position.

## AFTER OPERATION PROCEDURES

1. Check supply of twine or tape remaining in twine container. If supply is low tie the end of the existing twine or tape to the starting end of the new twine or tape with a square knot.
2. Clean any lint that may have collected in stringholder casting hole. A small pair of tweezers can be used for this purpose.
3. Cover tying machine with plastic bag used to ship tying machine.

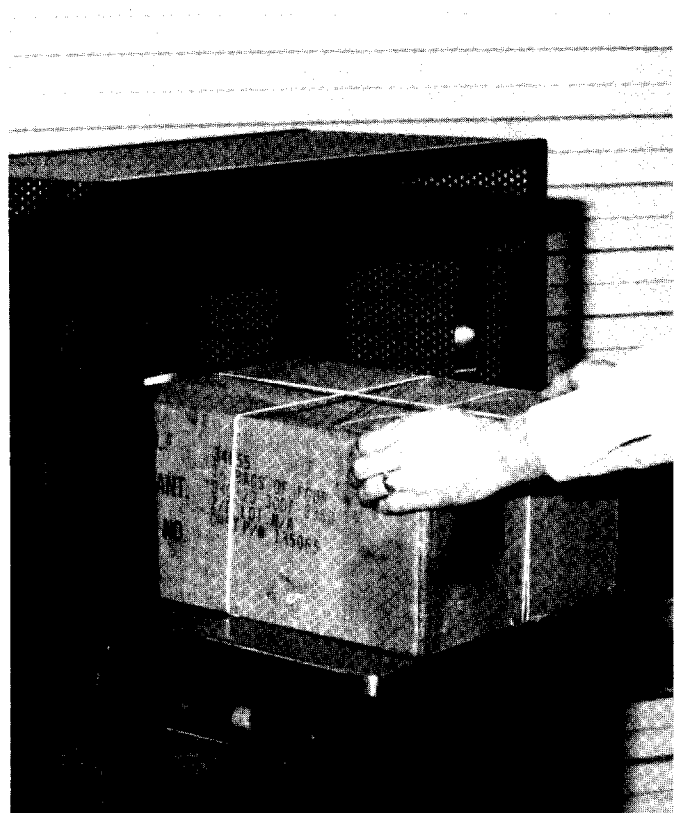
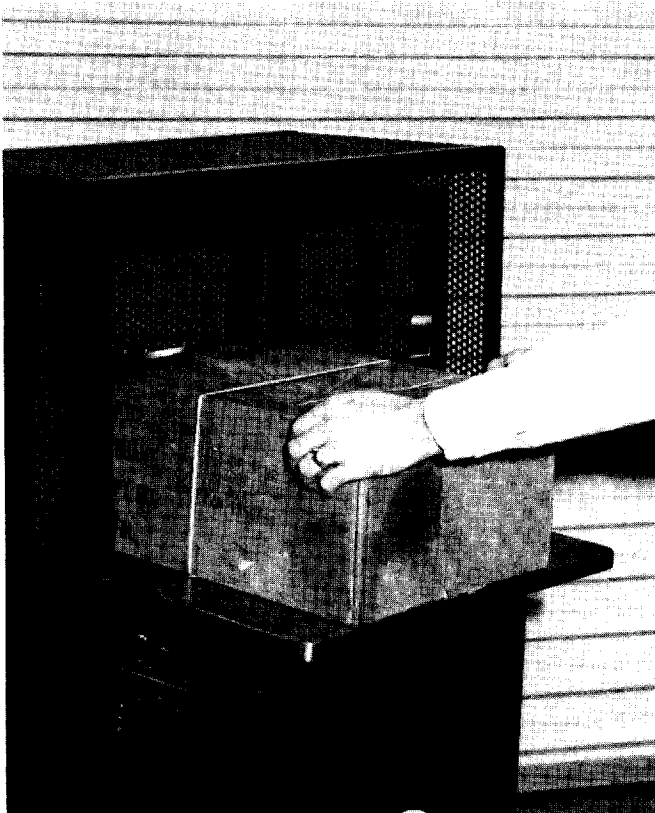

# Section IV

## Lubrication Requirements

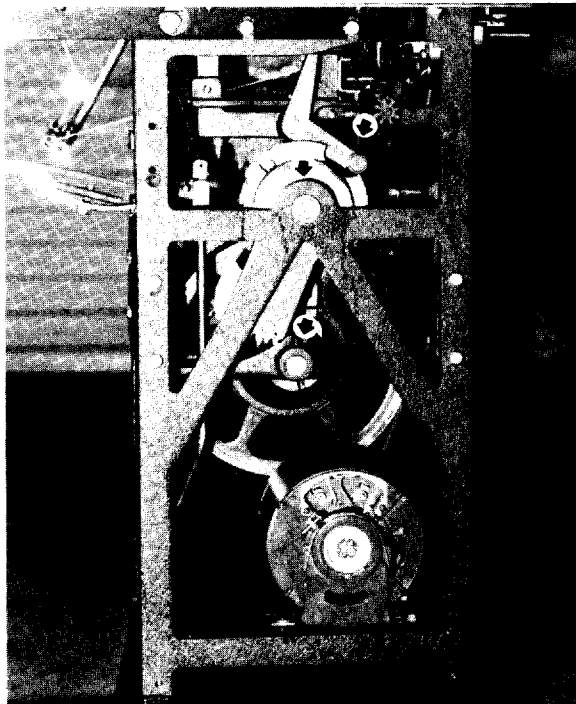
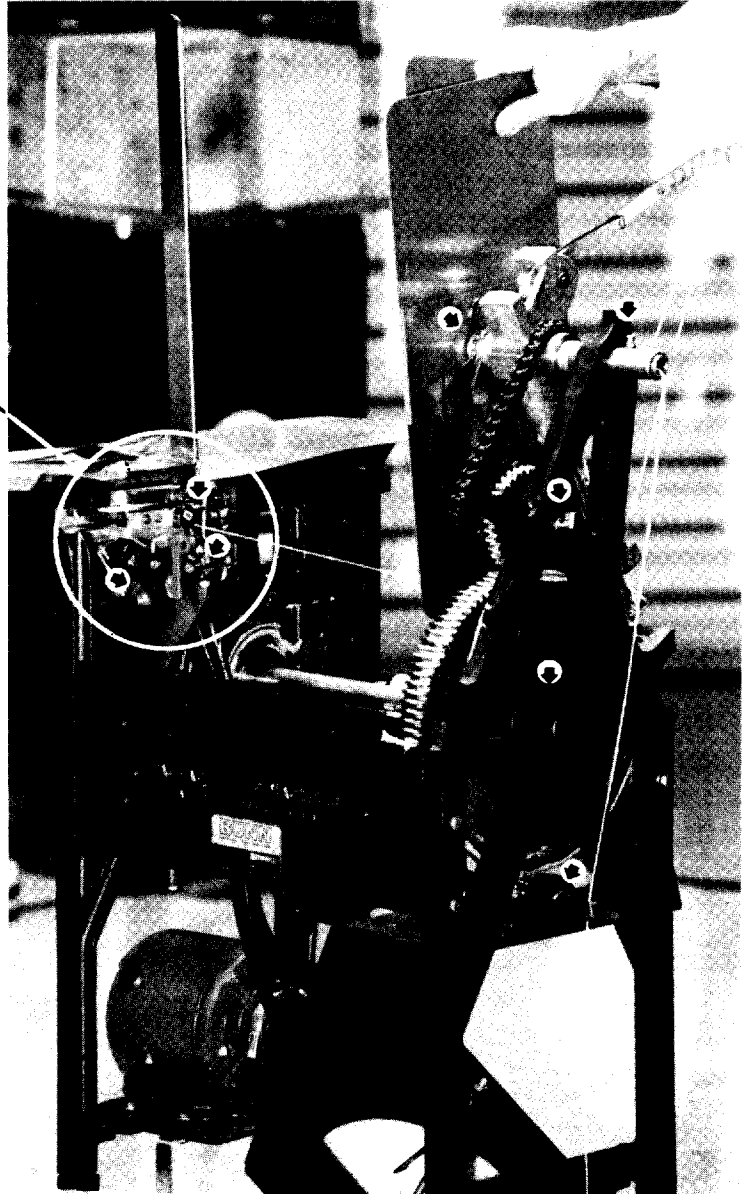
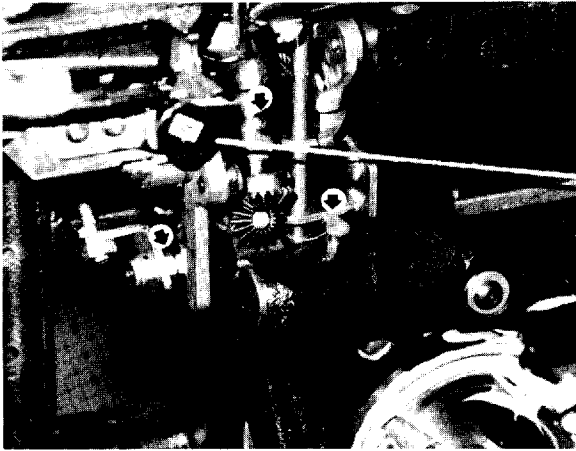

Arrows in photos identify oil holes. Refer to maintenance guide, page 13, for lubrication requirements.

# Section IV Maintenance

## INTRODUCTION

A good preventative maintenance program is a major step forward to assure trouble-free tying machine operation. In order to be effective, routine inspection, lubrication, and adjustment schedules must be established and followed.

For tying machines subjected to normal usage which is considered to be approximately 30 hours of operation weekly, the following maintenance and lubrication schedule should be followed. Substantial deviations from normal usage should require an adjustment in the indicated frequencies. The Lubrica-

tion Requirement has frequencies of 50 and 150 hours.

The following mechanical components should be checked daily: stringholder button holes for lint or twine build-up, knife conditions, V-belt tension, loose hardware and broken or weak knotter flat springs. The twine running tension should be checked on a monthly basis.

Daily any abnormal noises or loose components should be inspected and corrected. Power cord should be checked for fraying and the motor inspected for excessive dust or dirt.

LUBRICATION ITEM	FREQUENCY	
	50 HOURS	150 HOURS
<b>NOTE</b> - Apply several drops of SAE oil or equivalent unless otherwise specified. If necessary, refer to the exploded views in the parts list section of this manual for assembly part nomenclature.		
<b>KNOTTER HEAD ASSEMBLY</b>		
1. Oil cup (Knotter Head Pivot).	✓	
2. Two oil holes (encircles in red on machine).	✓	
3. Between knotter lever and knotter head subassembly.		✓
4. Around diameter of knotter roller.		✓
5. Knotter lock plunger.		✓
<b>STRINGHOLDER ASSEMBLY</b>		
1. Between knife trap pivot and knife trap lever assembly.	✓	
2. Between knife trap shoulder screw and knife trap lever assembly.	✓	
<b>MAIN TABLE ASSEMBLY</b>		
1. Around diameter of drawside lever assembly roller.	✓	
2. Between washer and drawside lever assembly.		✓
3. Between drawside lever assembly and main table subassembly.	✓	
4. Into three oil holes (encircles in red on machine).	✓	
5. Between stripper and main table subassembly so that stripper pivot pin is lubricated.	✓	
<b>NOTE</b> - Apply a liberal coat of recommended lubricant to the following unless otherwise specified.		
<b>DRIVE ASSEMBLY</b>		
1. Main gear cam surface.		✓
2. Knotter rack assembly cam surface and teeth.		✓
3. Cam riser cam surface.		✓
4. Cam switch cam surfaces.		✓
5. Apply several drops of SAE 10 oil to chain gear oil hole (encircled in red on machine).	✓	
6. Apply several drops of SAE 10 oil to the two oil cups.	✓	
7. Apply several drops of SAE 10 oil to the back frame two oil holes (encircled in red on machine).	✓	
8. Main shaft (encircled in red on machine).	✓	
9. Clutch shaft (encircled in red on machine).	✓	
10. Clutch fork pivot (encircled in red on machine).	✓	

# The Quality Knot Tells the Story

## THIS IS A *PERFECT KNOT*

A perfect knot, like the illustration, has two long even loops extending out one side of the knot with one short end and one long end, the body of the knot is tight and hard. The stripper should be on the line where the upper and lower jaws meet at the lip of the lower jaw and very little space between them as the stripper comes down to push the twine off of the knotter.

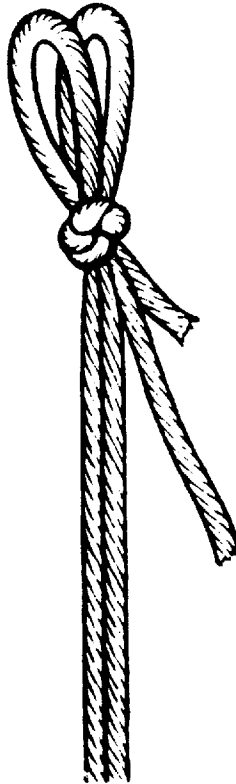

## *Important!*

Your **BUNN PACKAGE TYING MACHINE** will tie perfect knots every time, when in proper adjustment.



**B. H. BUNN COMPANY**  
2730 Drane Field Rd.  
Lakeland, Florida 33803  
Phone 813-647-1555  
1-800-222-BUNN

MANUFACTURERS OF QUALITY *Bunn Package Tying* MACHINES SINCE 1907

# Section V Trouble Shooting

This section of the manual contains a Table of Trouble Shooting Information for locating and correcting most of the troubles which may develop in the tying machine.

The tying machine is generally trouble free. However, the tying machine suffers the usual wear and misadjustment from normal use.

Careful inspection and accurate analysis of the





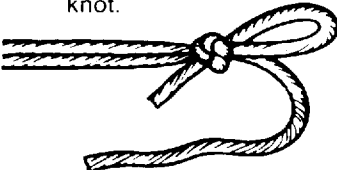
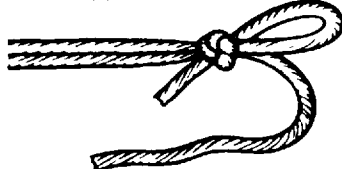
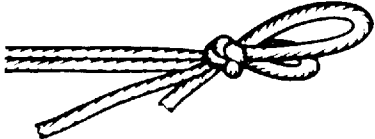

symptoms listed in the Table of Trouble Shooting Information will localize the trouble more quickly than any other method.

This manual cannot cover all possible troubles and deficiencies that may occur, therefore, if a specific trouble is not covered herein, proceed to isolate the major component in which the trouble occurs and then isolate and correct the trouble.

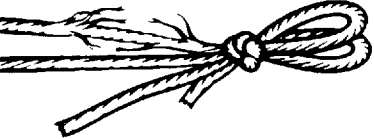
## Trouble Shooting Information

TROUBLE	POSSIBLE CAUSE	CORRECTIVE ACTION
A. Tying machine will not operate with power switch set to "on" position.	Electric power cord not plugged into receptacle. Circuit breaker tripped.  Broken or disconnected circuit wire.  Faulty power switch.	Plug electric power cord into receptacle.  Reset circuit breaker. If circuit breaker trips again, inspect and test for short in tying machine circuit of electric power cord. Correct defect as required.  Repair or replace broken wire.  Replace defective power switch.
B. Twine (or tape) breaks frequently in stringholder button.	Improper twine (or tape). Excessive stringholder button tension.	Use proper size of twine (or tape.) Readjust stringholder button pressure.
C. Half or single loop on knot. 	Piece of twine (or tape) wrapped around stringholder button shaft relieving tension on twine (or tape).	Depress and hold button release lever and remove bits of twine (or tape) using a small pair of tweezers. Then release button release lever.
D. One loop knot that slipped out. 	Excessive twine running tension.	Readjust to decrease twine running tension.
E. One long and one short loop. 	Improper twine (or tape). One loop catching in back of knotter throat, improper knotter release adjustment.	Use proper size of twine (or tape). Readjust knotter release.

# Trouble Shooting Information (cont.)

TROUBLE	POSSIBLE CAUSE	CORRECTIVE ACTION
<p>F. Break in twine in front of knot.</p> 	<p>Friction along twine (or tape) path.</p>	<p>Remove sharp edges from twine path in twine tension plate assembly, twine bracket, quill shaft, twine arm hub, twine arm assembly ring guides, drawback lever, and twine arm tip.</p>
<p>G. Ragged ends of twine at knot.</p> 	<p>Dull or knicked knife.</p>	<p>If knife is excessively knicked, replace. If knives continue being knicked, lubricate knife trap pivot points to assure that knife trap does not stick, allowing knife to remain in path of drawslide.</p>
<p>H. Loose knot and loops slightly shorter than normal.</p> 	<p>Loops release from knotter too soon, improper knotter release adjustment. Stripper too short.</p>	<p>Readjust knotter release. Replace stripper.</p>
<p>I. Short loops and tight knot.</p> 	<p>Improper balance between twine running tension and stringholder button pressure.</p>	<p>Check stringholder button pressure. Readjust twine running tension.</p>
<p>J. Cut loop ends.</p> 	<p>Stripper points shearing against side of knotter jaws when stripping.</p>	<p>Readjust stripper shear action, bend top front end of stripper down tapping with a light hammer.</p>
<p>K. Very short loops and long ends.</p> 	<p>Knot slipping by stripper. Improper gap between stripper point and knotter. Knotter flat springs broken or weak.</p>	<p>Realign stripper point and knotter. Replace knotter flat springs.</p>
<p>L. Twine (or tape) catches in stripper.</p>	<p>Stripper spring broken or weak.</p>	<p>Replace stripper spring.</p>
<p>M. Twine (or tape) pulls out of stringholder button.</p>	<p>Twine (or tape) improperly threaded.</p>	<p>Check stringholder button threading and rethread if necessary.</p>

# Section VI Parts List

The tying machine is identified by the Model Characteristic Data sheet and serial number stamped on the name plate located on the right side frame of machine.

Be sure to use both the model number and serial number when requesting part information or when ordering replacement parts.

Using the complete equipment identifier (model number and serial number) will ensure receipt of proper replacement part(s).

If your tying machine is equipped with a frame extension also be provided along with the complete model identifier when ordering replacement parts.

## Main Table Assembly

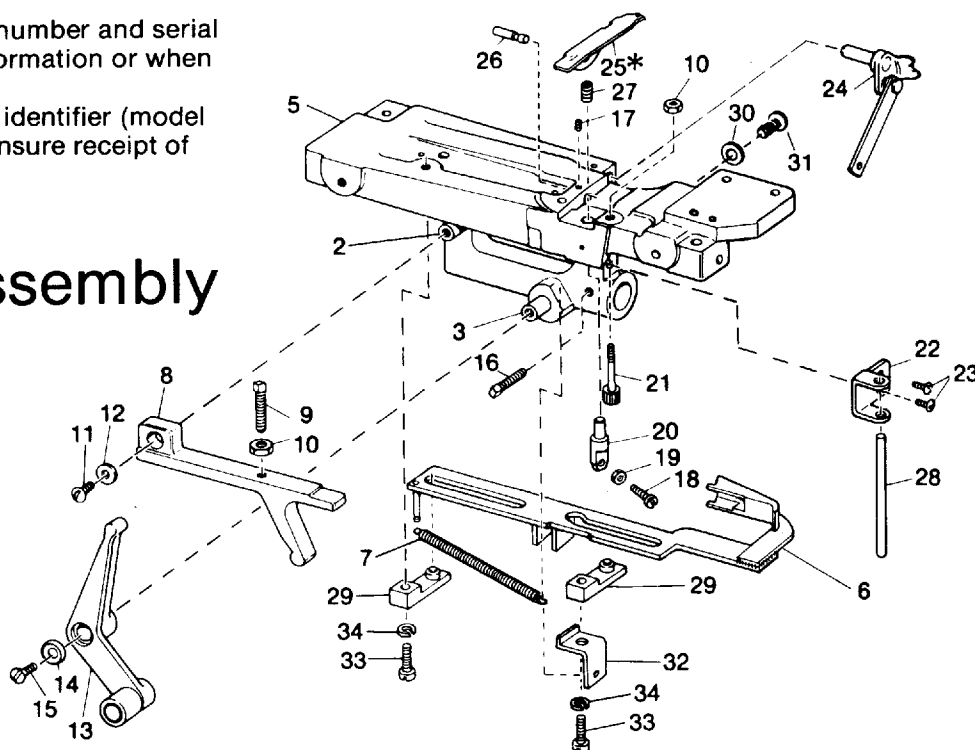

Use serial number when ordering all replacement parts.

Index Number	Part Number	Description	Number Required	Index Number	Part Number	Description	Number Required
1	008	Main Table Assembly	1	17	100121	Screw-Set, socket head, cup point, 8-32 x 1/4 in. long	1
2	081014	Riser Lever Stud	1	18	100018	Screw-Knotter release adjusting	1
3	081013	Drawslide Lever Stud	1	19	100191	Nut-Jam, hex, 1/4-28 NF	1
5	008009	Main Table Sub-Assembly. Note	1	20	081056	Stud-Knotter release	1
	008017	Main Table Sub-Assembly (Clamp Model) Note	1	21	100591	Stud-Knotter head stop	1
6	045034	Drawslide	1	22	083073	Guide-Riser pin	1
7	074059	Spring-Drawslide	1	23	100597	Screw-Round head, self tap 10-24 NC x 5/8 in. long	2
8	032003	Riser Lever	1	24	032035	Tip-Up Assembly	1
9	100124	Screw-Set, square head, half dog point	1	25*	052	Stripper	1
10	100150	Nut-Hex, 1/4-20 NC	2	26	083071	Pin-Stripper pivot	1
11	100098	Screw-Round head, 10-24 NC x 3/8 in. long	1	27	074006	Spring-Stripper	1
12	100131	Washer-Flat, 1/2 o.d. x 7/32 i.d. x 3/64 in. thk.	1	28	083060	Pin-Riser	1
13	032075	Drawslide Lever Assembly	1	29	070049	Drawslide Cap Assembly	2
14	100019	Washer-Drawslide Lever	1	30	100134	Washer-Drawslide Lever	1
15	100110	Screw-Flat head, slotted 1/4-20 NC x 1/2 in. long	1	31	100566	Screw Drawslide Lever	1
16	100596	Screw-Set, square head, cup point, 1/4-20 NC x 3/4 in. long	1	32	025288	Bracket Drawslide Spring	2
				33	100104	Drawslide Screws 1/4-20 x 1 in. long Filister Head	2
				34	100135	Washers Split-Lock 1/4 in.	2

— Tying Machine Model Number and Serial Number Required when Ordering.

\* Specify Type Twine or Tape Being Used.

NOTE: Sub-Assembly includes Items 2, 3, 10, 16, 17, 18, 19, 20, 21, 22, and 26.

# Knotter Head Assembly

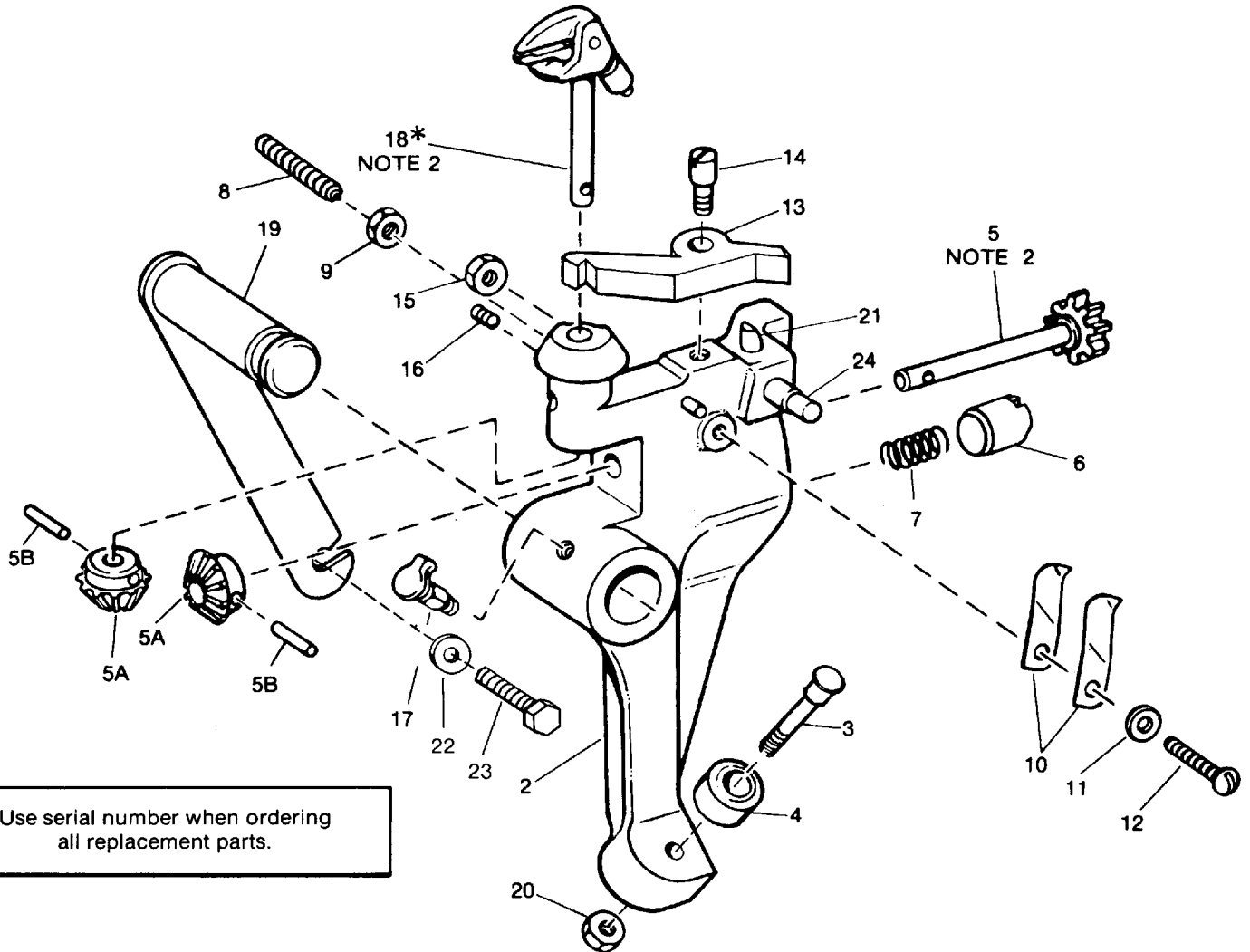

Index Number	Part Number	Description	Number Required	Index Number	Part Number	Description	Number Required
1	017—	Knotter Head Assembly	1	11	100131	Washer-Flat, No. 10	1
2	017035	Knotter Head Sub-Assembly(NOTE 1)	1	12	100192	Screw-Round head, 10-24 NC x 1 in. long	1
3	081020	Knotter Head Roller Stud	1	13	032042	Lever-Knotter	1
4	064008	Knotter Head Roller Assembly	1	14	100009	Screw-Shoulder, knotter lever	1
5	020157	Star Wheel & Miter Gear Assembly	1	15	100143	Nut-Hex, 10-24 NC	1
5A	020018	Miter Gear	1	16	100120	Screw-Set, socket head, cup point, 10-32 NF x 5/16 in. long	1
5B	100172	Tapper Pin	1	17	100017	Oil Cup	1
6	082003	Plunger-Knotter lock	1	18*	017—	Knotter Body & Miter Gear	1
7	074006	Spring-Knotter Lock	1	19	011004	Pivot Assembly-Knotter Head	1
8	100187	Screw-Set, Knotter lock, half dog point, 1/4-20 NC x 1 1/2 in. long	1	20	100560	Nut 5/16 - 18 Nylon Insert	1
9	100150	Nut-Hex, knotter lock, 1/4 x 20 NC	1	21	100174	Roll Pin	1
10	074013	Spring-Flat, knotter	2	22	100137	Washer -	1
				23	100119	Screw-Hex 5/16" x 1/2"	1
				24	081022	Stud-Tip-Up Lever	1

\* Specify Type Twine or Tape Being Used.

NOTES: 1. Sub-Assembly includes Items 3, 4, 20 and 21; 2. includes Items 5A and 5B.



# Stringholder and Knife Trap Assembly (Dual Tension)

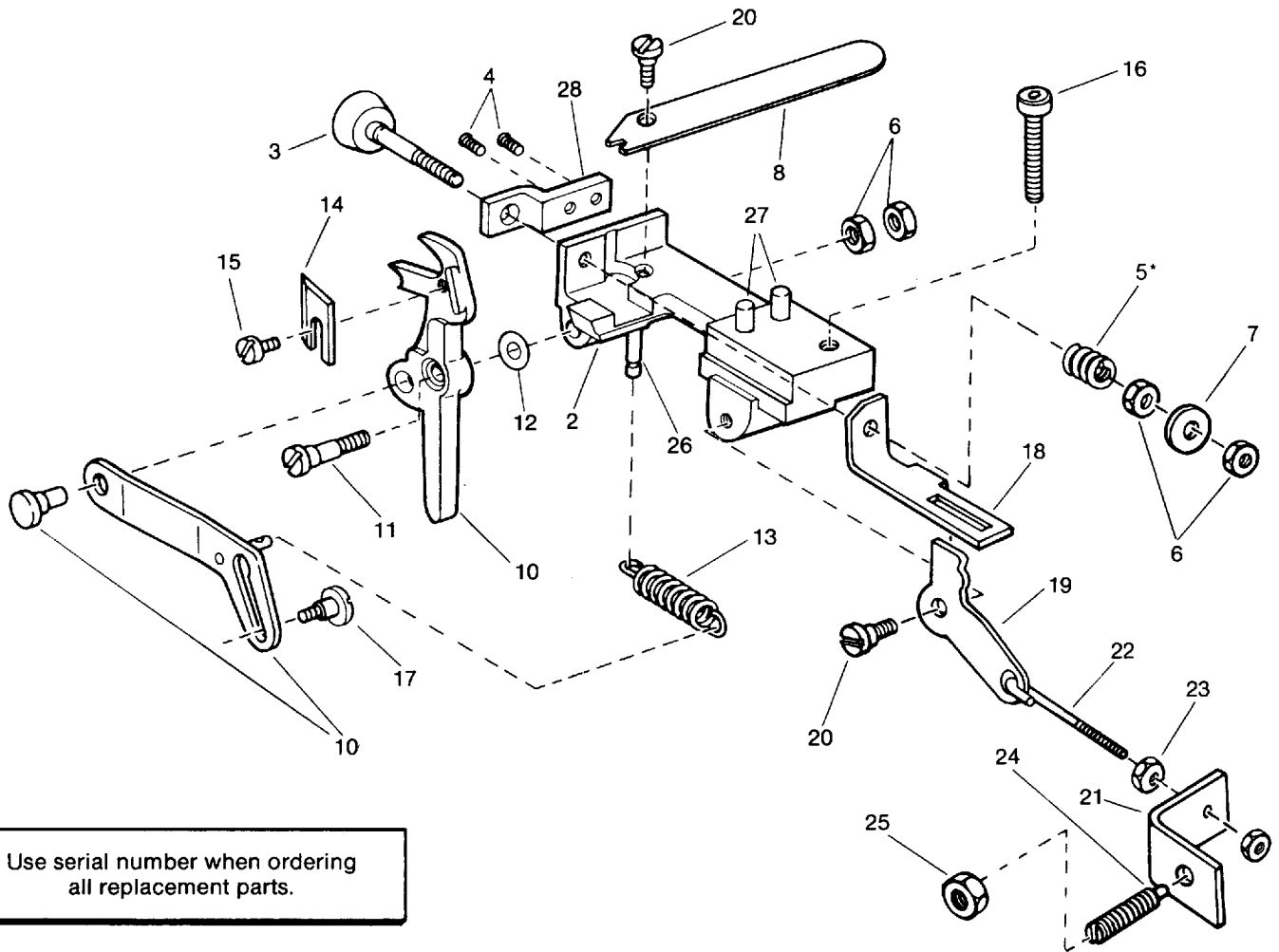

Use serial number when ordering all replacement parts.

Index Number	Part Number	Description	Number Required	Index Number	Part Number	Description	Number Required
1	030140	Stringholder Dual Tension Assembly	1	15	100090	Screw-Binder head, 8-32 NF x 1/4 in. long	1
2△	030142	Stringholder and Pins Sub-Assembly	1	16	100565	Screw Socket Head Cap	1
3	030047	Button-Stringholder	1	17	100011	Screw-Knife trap shoulder	1
4	100489	Screw 10-32 x 3/8	2	18	030084	Slide-Lever	1
5*	074010	Spring	1	19	030083	Pivot	1
6	100144	Nut-Hex, 10-32 NF	4	20	100088	Screw-Pivot Dual	2
7	100033	Washer-Stringholder-Button	1	21	030085	Angle	1
8	032157	Lever-Button Release	1	22	030086	Link	1
10	032159	Knife-Trap & Lever Assembly (short) & Pin Assembly	1	23	100425	Nut-Hex, 12-24 (2 way lock)	1
11	100646	Screw-Knife trap pivot	1	24	100187	Screw-Set, half dog point 1/4 x 20 NC x 1 in. long	1
12	100648	Spacer	1	25	100188	Nut-Hex, 1/4 x 20 ESNA	1
13	074011	Spring-Knife trap	1	26	100158	Spring Pin	1
14	021009	Knife-Package (total of 10)	1	27	100569	Groove Pin	2
				28	030145	Stringholder Face	1

\* Specify Type Twine or Type Tape Being Used.

△ Includes items 2, 4 26, 27 & 28

# Main Cam Assembly

Use serial number when ordering all replacement parts.

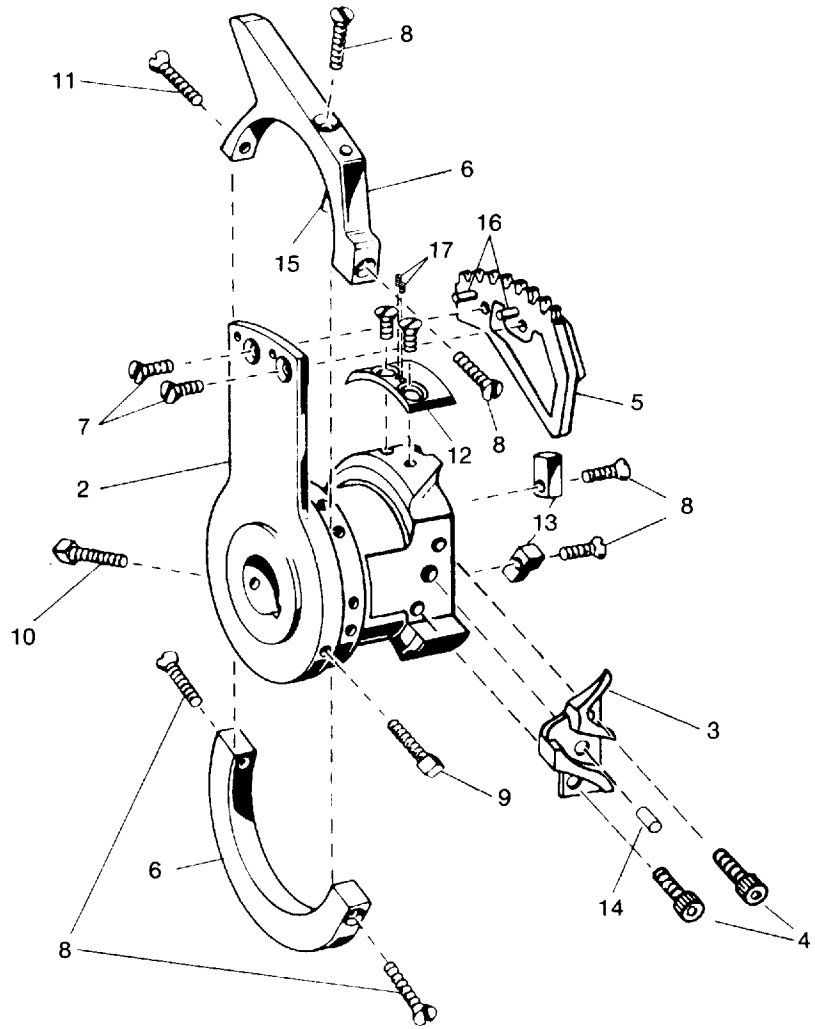

Index Number	Part Number	Description	Number Required	Index Number	Part Number	Description	Number Required
1	009084	Main Cam Assembly	1	9	100128	Screw-Set, square head, cup point 5/16 - 18 NC x 1-1/4 in. long	1
2△	009009	Main Cam	1	10	100127	Screw-Set, square head, cup point 5/16-18 NC x 1-1/2 in. long	1
3	009025	Switch-Cam, knotter head (includes pin)	1	11	100095	Screw-Machine, flat head 10-24 x 5/8 in. long	1
4	100109	Screw-Socket head, cap, 1/4-20 x 5/8 in. long	2	12	209007	Riser Cam	1
5	020135	Rack-Knotter cam	1	13	009026	Clutch-Kickout Block (two required for cross-tie) only	1
6	009032	Ring Cam (Set)	1	14	100161	Groove Pin	1
7	100328	Screw-Machine, flat head 12-24 NC x 5/8 in. long	4	15	100160	Groove Pin	1
8	100326	Screw-Machine, flat head 10-24 NC x 7/8 in. long	6	16	100372	Roll Pin	2
				17	101395	Screw-Soc Set M5 x 6 Lg Cone Pt.	2

— Tying Machine Model Number and Serial Number Required When Ordering.

△ Includes all items #2 through #17

# Kickout Mechanism

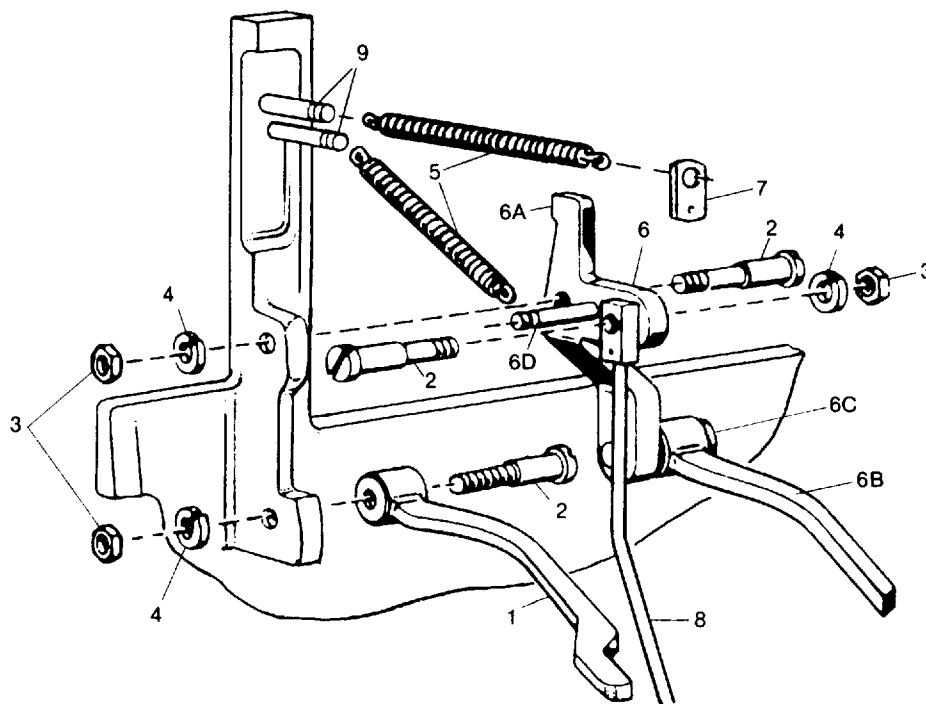

Use serial number when ordering  
all replacement parts.

Index Number	Part Number	Description	Number Required	Index Number	Part Number	Description	Number Required
1	032018	Lever-Clutch Kickout	1	6A	011006	Trip-Bell Crank	1
2	100005	Screw-Trip Rod	3	6B	060003	Wedge-Kickout lever	1
3	100151	Nut-Hex, 1/4-28 NF	3	6C	081002	Stud-Kickout lever wedge	1
4	100135	Washer-Split Lock 1/4	3	6D	100158	Groove Pin	1
5	074005	Spring-Trip, Return	2	7	030016	Anchor Spring	1
6	011007	Bell Crank Trip with lever, stud and pin	1	8	006099	Trip Rod	1
				9	100157	Groove Pin	2

—Tying Machine Model and Serial Number Required When Ordering.

# Mainshaft, Main Gear/Chain Gear Assemblies

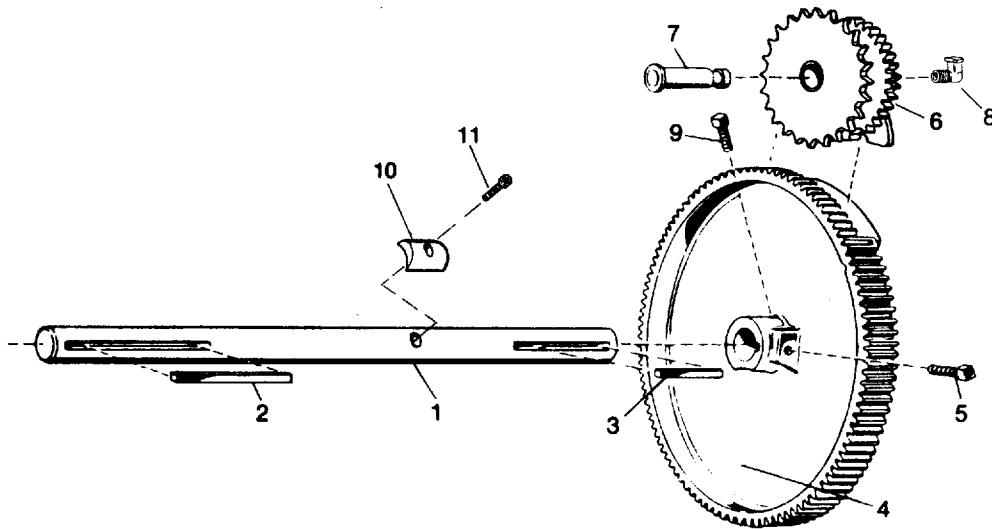

Use serial number when ordering  
all replacement parts.

Index Number	Part Number	Description	Number Required	Index Number	Part Number	Description	Number Required
1	012053	Main Shaft	1	6	020245	Chain Gear Assembly	1
2	083057	Key-Cam Wheel	1	7	081032	Stud-Chain Gear	1
3	083074	Key-Main Gear	1	8	100087	Oil Cup - 90°	1
4	020004	Main Gear	1	9	100128	Screw-Set Square Head, Cup point 5/16-18 x 1-1/4 in. long.	1
5	100127	Screw-Set Square Head, cup point, 5/16-18 x 1-1/2 in. long	1	10	009137	Cam, Main Shaft	1
				11	100368	1/4-20 x 1" Socket head Cap	1

— Tying Machine Model and Serial Number Required When Ordering.

# Clutch Assemblies

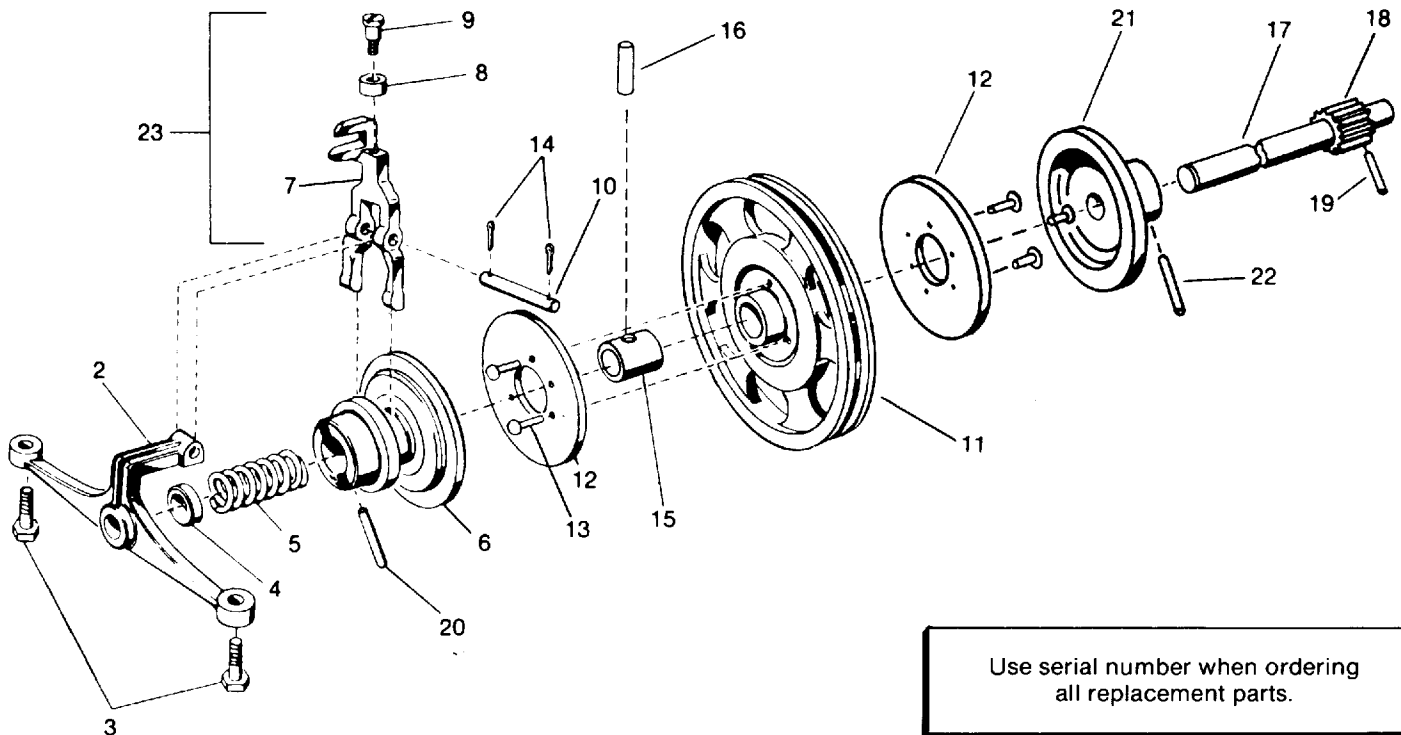

Use serial number when ordering all replacement parts.

Index Number	Part Number	Description	Number Required	Index Number	Part Number	Description	Number Required
1△	019018	Clutch Assembly	1	13	100181	Drive Screw	6
2	013096	Lower-Bearing	1	14	100633	Hitch Pin	2
3	100115	Screw-Hex, head, 5/16-18 x 1 in. long	2	15	013099	Bearing Clutch	1
4	094005	Collar Clutch Shaft End	1	16	100601	Roll Pin	1
5	074003	Spring Clutch	1	17	012009	Shaft	1
6	024002	Clutch Member-Outer	1	18	020020	Pinion-Clutch Shaft	1
7	071001	Fork-Clutch	1	19	100171	Taper Pin, No. 3 x 1-1/4 in. long	1
8	064002	Roller-Clutch Fork	1	20	083075	Pin-Clutch Pulley	1
9	100002	Screw-Clutch Fork Roller	1	21	024001	Clutch Member-Inner	1
10	083056	Pin-Clutch Fork Pivot	1	22	100169	Taper Pin, No. 3 3 x 1-3/4 in. long	1
11	019093	Pulley	1	23	071004	Clutch Fork Assembly	1
12	024003	Clutch Disc	2				

— Typing Machine Model Number and Serial Number Required When Ordering.  
 △ Includes all items above except #2, 3, 7, 8, 9, 10, 14, & 23

# Twine Arm Assembly

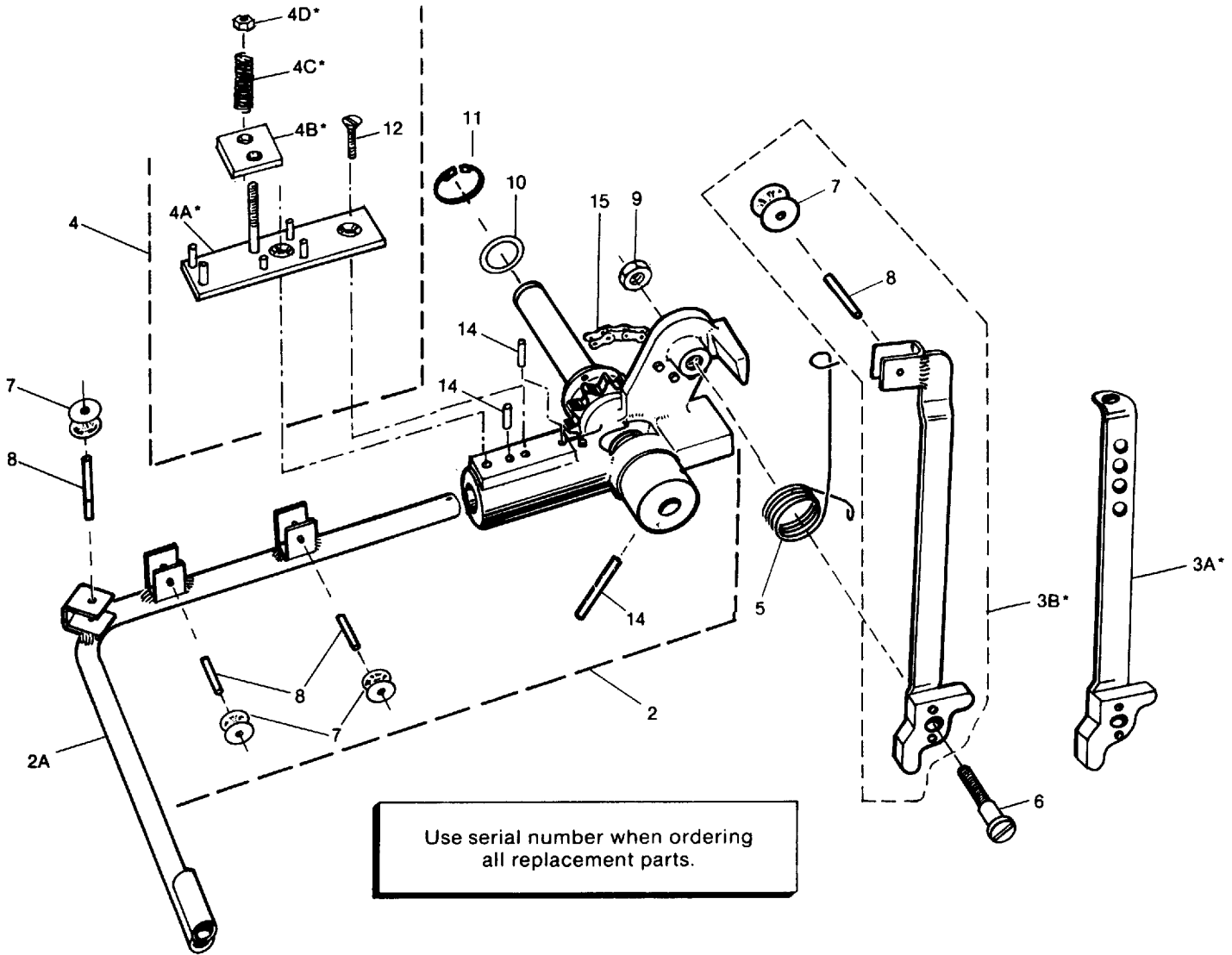

Use serial number when ordering all replacement parts.

Index Number	Part Number	Description	Number Required	Index Number	Part Number	Description	Number Required
2Δ	035105	Hub, quill, sprocket & twine arm assembly	1	5	274005	Spring-drawback torsion	1
2A	033181	Twine Arm	1	6	101876	Screw-drawback Lever Pivot	1
3A*	032189	Drawback lever assembly- TWINE	1	7	064037	Roller	3 or 4
3B*	032193	Drawback lever assembly- TAPE	1	8	100649	Pin-spring 5/32" dia. x 3/4"	3 or 4
4	130226	Tension Assembly	1	9	101518	Nut-hex M8 x 1.25	1
4A*	130227	Tension Plate Sub-Assembly	1	10	100022	Washer-twine arm	1
4B*	130224	Plate, Tension Pressure	1	11	100052	Retaining ring (Truarc 5108-75)	1
4C*	074062	Spring, Tension	1	12	101323	Screw-socket flat head	2
4D*	100586	Nut, 2-way lock	1	14	100295	Roll pin-3/16" dia x 1-1/2"	3
				15	135025	Chain	1

Δ Include all above items #8 & #9  
 \*Specify type twine or Poly tape used  
 Note: Assemble with Loctite No. 242

# Miscellaneous / BT-17

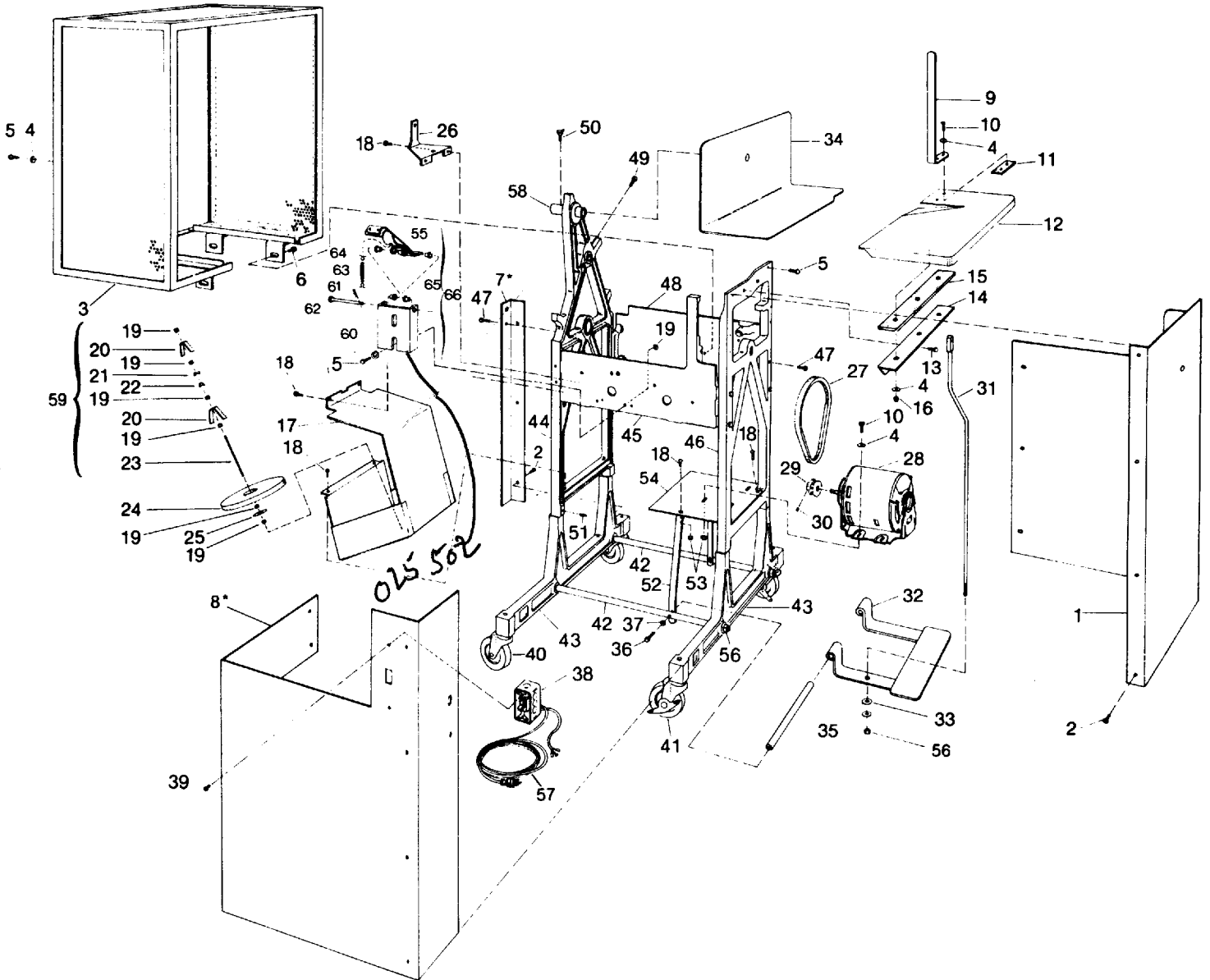

Use serial number when ordering all replacement parts.

# Miscellaneous / BT-17

Index Number	Part Number	Description	Number Required	Index Number	Part Number	Description	Number Required
1*	038295	Panel Ass'y.-Lower Front & Right Side	1	36	100238	Screw-Hex. Head Cap-1/4-20 N.C. x 1-1/4 Long	2
2	100255	Screw-Pan Head Slotted-No. 8-32 N.C. x 1/2 Long	7	37	100135	Washer-Split Lock-1/4 I.D.	2
3	132261	Twine Arm Guard	1	38	050286	Cord Set Assembly-Grounded (3 Wire-115V/230V-60Hz)	1
4	100280	Washer-Flat-5/16 I.D.	11	38A	050038	Cord	1
5	100115	Screw-Hex. Head Cap-5/16-18 N.C. x 1" Long	2	38B	050232	Switch	1
6	100298	Screw-Flanged Hex. Head Cap-1/4-20 N.C. x 1/2 Long	4	38C	050052	Relief-Cord	1
7*	025410	Whiz-Loc Mounting Bracket Ass'y.-Lower	1	38D	050285	Box-Electrical Assembly	1
8*	038294	Right Rear, Panel Assembly-Lower	1	38E	100097	Screw	1
9	127015	Left Side, Standard	1	38F	100131	Washer	1
10	100107	Screw-Hex. Head Cap-1/4 20 N.C. x 5/8	10	38G	100132	Washer	1
11	077013	Pad-Front Table Short	1 (REF.)	38H	100143	Nut	1
12	007032	Front Table	1 (REF.)	39	100101	Screw-Round Head Slotted-No. 10-32 N.F. x 1/2 Long	2
13	100119	Screw-Hex. Head Cap-5/16-18 N.C. x 1/2 Long	2	40	135047	Caster-3" Diameter	2
14	025362	Bracket-Front Table	1	41	135051	Caster-3" Diameter with locking device	2
15	077012	Pad-Front Table Long	1 (REF.)	42	006064	Base Tie Rod-Standard Side Frame	2
16	100188	Nut-Hex-1/4-20 N.C.-ESNA	3	43	005082	Base-High	2
17	110050	Twine Enclosure Assembly	1	44	001006	Frame-Rear	1
18	100490	Screw-Button Head Socket Cap-1/4-20 N.C. x 1/2 Long	8	45	003004	Frame-Left Side	1
19	100284	Nut-5/16-18 N.C.-Twin Whiz-Loc	7	46	002062	Frame-Front	1
20	070075	Twine Cone Pilot	2	47	100113	Screw-Hex. Head Cap-5/16-18 N.C. x 1-10 <sub>2</sub> Long	8
21	025350	Bracket Twine Cone Holder	1	48	004001	Frame-Right Side	1
22	100285	Wing Nut-5/16-18 N.C.-Type A	1	49	100128	Screw-Sq. Head Set-5/16-18 N.C. x 1-1/4 Long-Knurled Cup Point	1
23	081071	Twine Cone Pilot Stud	1	50	100017	Oil Cup	1
24	077016	Pad-Twine Cone	1	51	100130	Screw-Socket Set-5/16-18 N.C. x 5/16	2
25	100279	Washer-Fender 11/32 I.D.	1	52	025075	Bracket-Motor Mounting Plate	2
26	025361	Bracket-Rear Twine Guide	1	53	100286	Nut-Flanged Hex.-1/4-20 N.C.-Whiz-Loc	6
27	040003	V-Belt 2330 (33" Circumference)	1	54	130204	Plate-Motor Mounting	1
28	039001	Motor-Single Phase (115V, 60Hz, 1/4 H.P., 1725 R.P.M.)	1	56	100152	Nut-3/8-16 Hex Heavy	5
29	019—	Motor Sheave	1	57	050029	Cable Tie-6-3/4" Lg. Stand. Size	2 (REF.)
30	100262	Screw-Socket Set-5/16-18 N.C. x 3/8 Long-Knurled Cup Point	1 (REF.)	58	013006	Bronze Bearing	1
			Purchase with Motor Sheave	59	070076	Twine Holder Assembly	1
31	006099	Trip Rod Assembly-High Base	1	60	025432	Bracket-Brake Mount.	1
32	059027	Trip Pedal Assembly	1	61	100297	Hitch Pin	1
33	100420	Washer-Flat Wrought-7/16 I.D.	3	62	083058	Pin-Brake Arm Pivot	1
34	010150	Back Table Assembly	1	63	074018	Spring	1
35	006100	Rod-Trip Pedal Pivot	1	64	100182	Cotter Pin 1/32" x 1"	2
				65	100684	Bronze Bushing	4
				66	014040	Brake Assy	1

△ Order Items #11 and #15 when Ordering Item #12  
 \*Includes 077043 Pads as Requested  
 \*\*Includes 077049 Pad as Requested

Use serial number when ordering  
 all replacement parts.



---

# Two ways to keep your BUNN tying machine in top operating order-

---

## 1 Use only BUNN twine or tapes

Bunn has the right tying twines for every job . . . cottons, rayons, nylons, poly tapes and heavy-duty twines with a complete selection of tensile strengths. BUNN twines have high speed quality characteristics that are guaranteed to match your machine performance. BUNN also has heavy-duty plastic twines for hand tying. Soft, smooth, kind to hands, and comes in handy container-feed cartons.

---

## 2 Use the right twine for the job

**Rayon** A continuous filament, high tensile strength fiber with very little stretch and minimal lint build-up.

**Cotton** A high quality-grade natural fiber.

**Hy-Ty** A high, wet modulus rayon that is clean, white and is the finest twine on the market.

**Special Hy-Ty** A blend of the best characteristics of both cotton and polyester offering a high yield and strength with economy.

**Cable Cord** A special twisted cotton twine with excellent elastic properties for packaging.

**Polyester** A high grade synthetic fiber that provides maximum tensile strength, clean appearance and minimal lint build-up.

**Nylon** A coarse grade industrial twine with unexcelled properties of elasticity, strength and knot holding capabilities of quality twine.

**Poly Tape** A low density polyethylene tape that is a soft non-abrasive blend with all the strength and tying characteristics of conventional twine yet is still economical.

---